

MAGIC WAND KIT Instructions

Kit Features

- Threaded tip assembly for easy replacement
- Requires a blank - 3-1/2"
- Overall length: approximately 14-1/4"

* Optional Bookmark Mandrel (BKMARKMAN) if turning your own cabochon on the end.

Required Accessories

- 7mm mandrel
- 3/8" drill bit (DB3/8 or DB3/8CT)
- 2-pc. bushing set (PKWAND-BU)
- 3/8" barrel trimmer
- Glue (We recommend thick "gel" CA glue—GTHICK2)
- Sanding and finishing supplies

Diagram A - Parts and Assembly

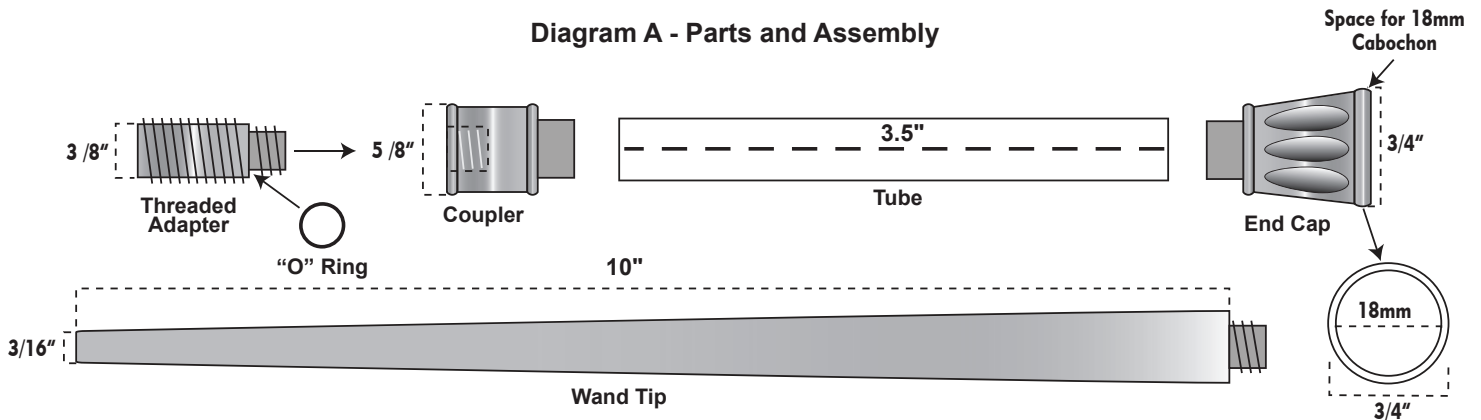

BLANK PREPARATION

Cut your blank approximately 1/16" longer than the tube to allow for squaring with the barrel trimmer. Use a medium **drill** speed to drill the blank. Raise the bit from the wood every 1/4" to 1/2" to allow the chips to clear from the flutes of the drill bit. Don't force the drill bit; use an even pressure and let the bit do the work. After drilling the blank, sand the exterior of the brass tube to roughen its surface and use **CA glue** to glue the tube inside the blank. **Sand** or barrel trim to **square** the ends of the blank.

TURNING THE WAND HANDLE

Set up your mandrel as shown in Diagram C. **Turn** the pen blank to the bushing diameter at the ends. **Sand** with abrasives and **finish** with your choice of polish.

TURNING THE CABOCHON

We recommend the **Bookmark Mandrel** (BKMARKMAN) to turn the 18mm Cabochon.

ASSEMBLY

(Line up finished parts according to Diagram A)
To avoid damage to components when assembling, use a vise with covered jaws or one of WoodTurningz' pen presses.

1. Press the End Cap into one end of the barrel.
2. Press Coupler into the opposite end of the tube.
3. Place "O" ring on the Threaded Adapter between the two different threads.
4. Screw smaller threaded end into the Coupler
5. Screw Wand Tip onto the opposite end of Threaded Adapter.
6. The wand is now ready for use.

Diagram B - Bushings

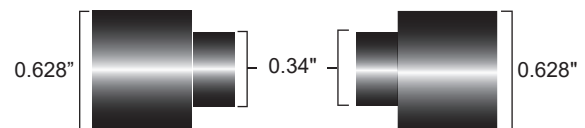
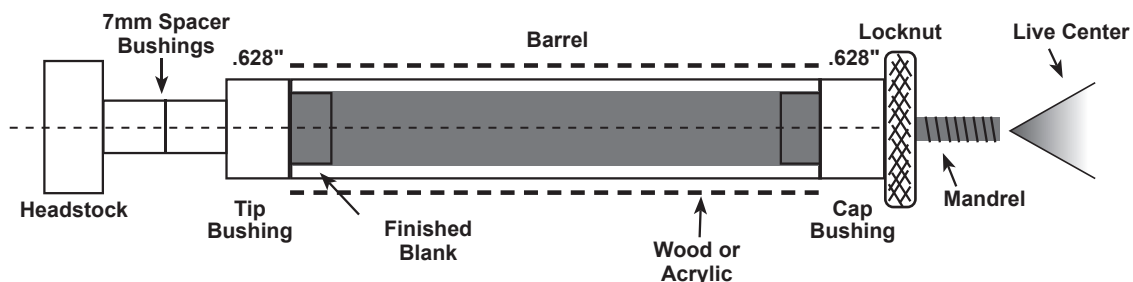
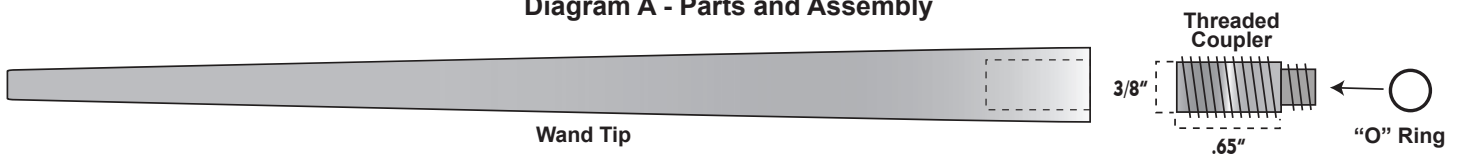

Diagram C - Turning the Pocket Stylus



OPTIONAL WAND TIP Instructions

Diagram A - Parts and Assembly



BLANK PREPARATION

The blank size will vary based on the profile of your design. Generally, the size of your wood or acrylic blank should be 1" x 1" x 10" long. Mark the center of the blank on the end. Using a medium drill speed, drill an 8mm diameter hole 1-3/8" deep. Raise the bit from the wood every 1/4" to 1/2" to allow the chips to clear from the flutes of the drill bit. Don't force the drill bit; use an even pressure and let the bit do the work.

OPTIONAL USE OF TAP SET: Instead of drilling an 8mm hole, drill a 5/16" hole and tap a 3/8" x 16 tpi thread.

OPTION 1

TURNING BETWEEN CENTERS

Set up the blank between centers as shown in Diagram B. **Turn** the blank to your own profile design. **Sand** with abrasives and finish with your choice of polish.

Required Accessories & Materials

- 8mm drill bit (included in PK-BS1 kits above) or 11/32"
- Optional Tap Set (BSTAPSET - with 3/8" x 16 tpi thread)
- Glue (Epoxy)
- Sanding and finishing supplies
- Blank size: Approximately 1" x 1" x 10" long

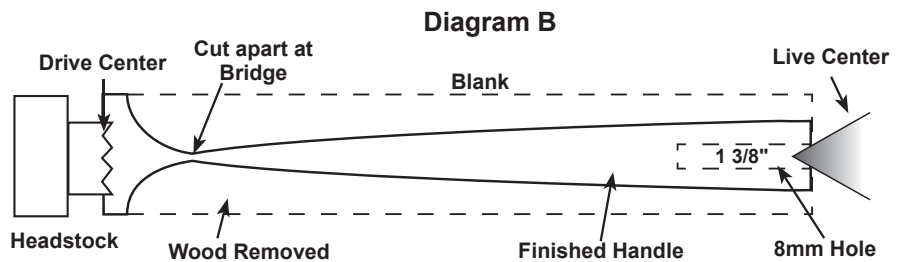

OPTION 2

TURNING USING THE LATHE CHUCK

Set up the mandrel as shown in Diagram C. Screw the wood or acrylic blank onto the chuck's threaded end into the hole you drilled. You can use a wrench on the flats milled into the chuck to tighten. Mount the screw chuck onto your lathe. Now secure the blank by engaging the tailstock live center for support. Your blank is now ready to turn. Once you have rounded the blank to remove the edges, the tailstock can be removed from the lathe while you continue turning.

Turn the blank to your own profile design. The bottom diameter at the base of the piece may be less than the chuck diameter, so measure the top of the wand to match the wand's outside diameter to be turned. Sand with abrasives and finish with your choice of polish.

Required Accessories & Materials

- Bottle stopper screw chuck kit (PK-BS1-MJ) for 1"x 8tpi lathe or chuck kit with adapter for (PK-BS1-M) for 3/4"x16tpi lathe
- 8mm drill bit (included in PK-BS1 kits above) or 11/32"
- Optional Tap Set (BSTAPSET - with 3/8" x 16 tpi thread)
- Glue (Epoxy)
- Sanding and finishing supplies
- Blank size: Approximately 1" x 1" x 10" long

Diagram C

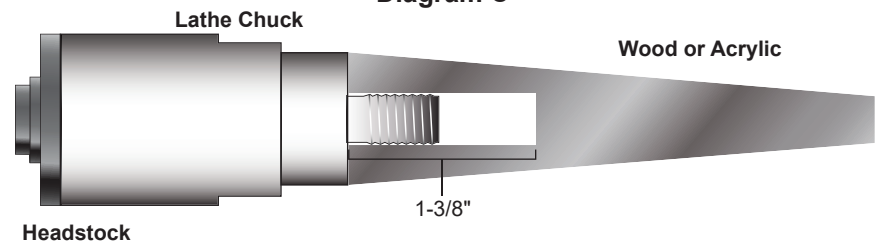

ASSEMBLY

WoodTurningz recommends using Epoxy when assembling the wand. Spread epoxy over the threads of the Threaded Coupler. Be sure not to get any epoxy on the outside of the wand. Screw the piece onto the wand to secure. When dry, the wand is ready to use.