

## BOOKMARK, RULER, JEWELRY & KEYCHAIN KITS

### Instructions

#### Kit Features

- Fun, simple way to utilize scraps of wood or acrylic
- Quick project to make for gifts
- Turn to either 18 or 20mm depending on the kit (all 20mm kits have a "2" in the part number i.e. RULER2-xx, BKM2-FLORAL-xx, PKKEY2xxx)

#### Required Accessories & Materials

- Glue (We recommend the thick "gel" CA glue—GTHICK2)
- BKMARKMAN for 18mm kits (optional)
- BKMARKMAN2 for 20mm kits (optional)
- BKMARKMAN3 for 25mm kits (optional)
- Sanding and finishing supplies

**Diagram A** Wood Waste Block

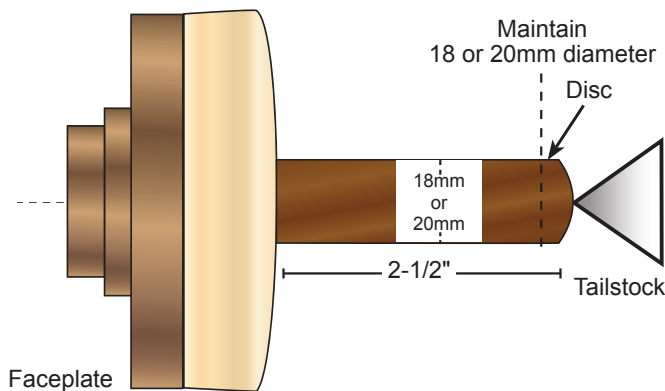

**Blank Preparation and Turning**

**Diagram B**

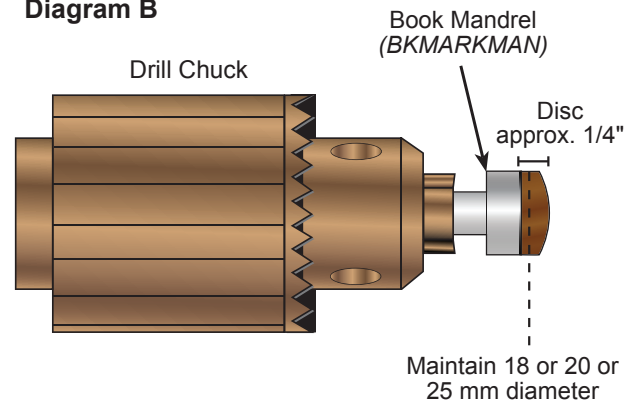

While a wood turning chuck will make turning bookmark kits a breeze, you don't have to have one. Here are two alternate methods for making bookmark kits that are fast and easy!

#### METHOD 1 (DIAGRAM A): USING A FACEPLATE

Use the faceplate that came with your lathe. When using your faceplate, attach a "waste block" of wood by screwing it onto the faceplate and then glue your wood or acrylic blank onto the wood block with CA thick glue. We recommend using a standard 3/4" x 3/4" x 5" pen blank cut in half so it is roughly 3/4" x 3/4" x 2.5" (the full 5" blank length will be difficult to turn while keeping it glued to your waste block). Slide the tailstock up to the end of the blank. Turn the blank down to a finished diameter of either 18 or 20mm (depending on which kit is being made). After the blank is round slide the tailstock back. Now dome over the end of the disc.

Sand lightly with fine-grit sandpaper and Micro Mesh. Once sanded to the desired level, apply a small amount of polish or finish of choice to complete the disc. Using a parting tool, gently part off the end of the blank to remove the finished disc (part gently so you don't pull the blank from the waste block). You may also want to slightly undercut the disc which will help it sit nicely on the bookmark.

Once you get the rhythm of turning, polishing, and parting off these little discs, you won't believe how quickly you can produce many fun little bookmarks!

#### METHOD 2 (Diagram B): Using the Bookmark Mandrel

You can use WoodTurningz BKMARKMAN or BKMARKMAN2 with a drill chuck to turn individual slices of wood or acrylic into bookmarks. Slice your material approximately 1/4" thick and round off the corners using a belt sander or other safe method. You can also round your material before slicing for greater ease. Use a strong double sided tape to attach the piece to the mandrel. Round your piece to mandrel diameter and then, dome over the disc to a pleasing shape.

Sand lightly with fine-grit sandpaper.

Once sanded to the desired level, apply a small amount of polish or finish of choice to complete the disc. You have some leeway in how you "dome" the blank's end.

#### ASSEMBLY (Diagram C)

Using fine-grit sandpaper, carefully rough up the plated surface on the round area of your bookmark where you will glue on the disc. Glue the disc in place using a small amount of thick CA glue or Epoxy glue.

**Diagram C**  
**Bookmark Assembly**

