

**REVISED**

# Revolver Click Pen Kit

**Kit Features:**

- Innovative click mechanism
- “Revolver” centerband spins as the refill extends
- Trigger Clip retracts the refill
- Easy to Turn With Straight Tube
- Minimal Parts-easy to assemble
- Available in multiple finishes
- Overall Length: 5-9/16”

**Required Accessories:**

- 7mm Pen Mandrel
- Drill Bit:#PK10-10
- Bushing Set(2 pc): #PKREVB
- Barrel Trimming set: #PKTRIM10 or pen blank squaring jig with a 10MM sleeve
- Live Tailstock or Mandrel Saver
- 2 part Epoxy or Thick CA (Cyanoacrylate) Glue
- Pen Blank Minimum Size: 3/4”x3/4”x2-1/8”

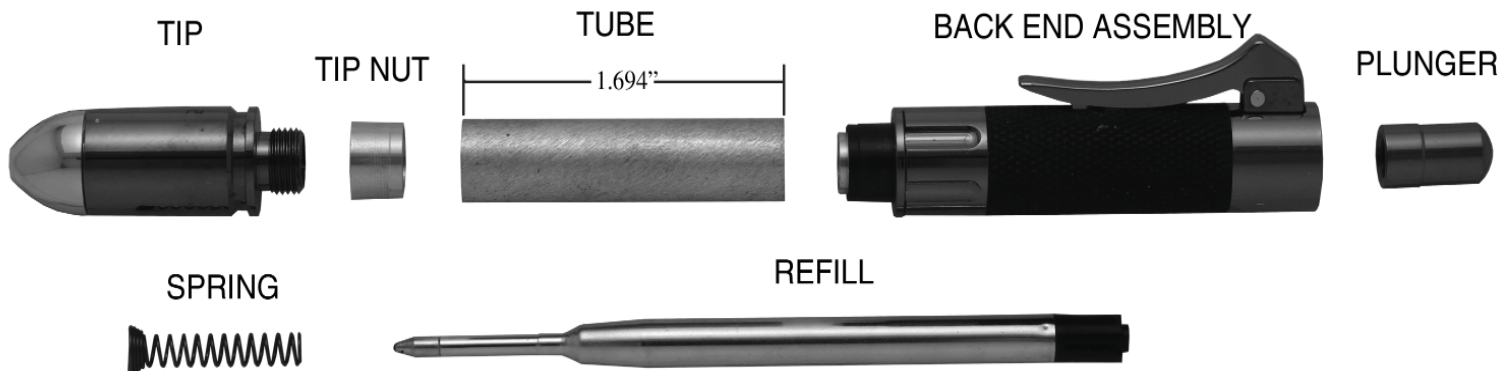
**DIAGRAM A / PARTS LAYOUT****Preparing the Blank:**

- Cut one blank to the length of the tube, adding 1/16” for squaring off (approx 2-1/8”).
- Drill 10MM hole lengthwise through the blank.
- Spread glue over the tube, insert the tube into the blank with a twisting motion to spread the glue evenly inside.
- Center the tube lengthwise inside the blank.
- When the glue is dry, square the ends of the blanks, making sure the trimmed ends are 90° to the tube. Use a 10MM barrel trimmer, or a pen blank squaring jig with a 10MM sleeve on a disc sander. Take the excess material down flush to the ends of the tubes. Do not trim past the end of the tube since this may interfere with the operation of the mechanism and assembly. Use a barrel trimmer to clean the inside of the tube.

## DIAGRAM B / TURNING THE BLANKS

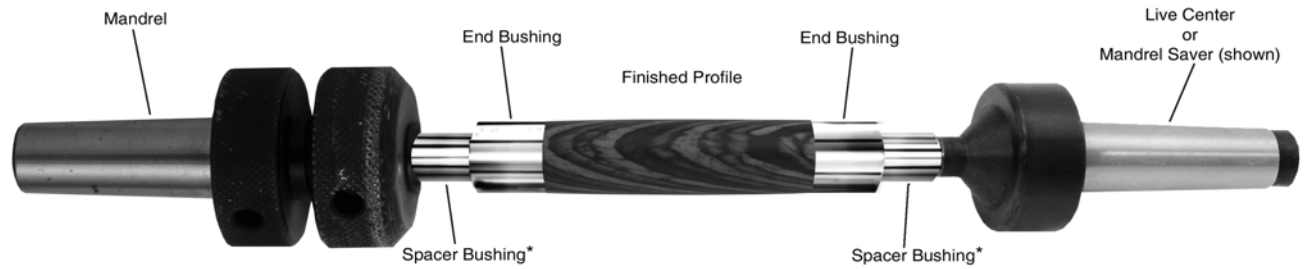

\*Optional

## Turning the Blank:

- Mount the bushings and blank according to diagram B.
- If using Live Center and threaded nut: Add spacer bushings until they cross the threaded area. Thread on the knurled nut and hand tighten to hold all components in place.
- Slide the Tailstock up snugly against the Mandrel shaft, inserting the live center point into the Mandrel dimple. Lock Tailstock.
- Hand tighten the quill adjustment on the tailstock to steady the mandrel. Do not over-tighten, it could damage the mandrel shaft.
- When using Mandrel Saver, there is no need for extra spacer bushings or the knurled nut. Slide tailstock directly against bushings and tighten until blank and bushings are secure. You may want to add spacer bushings for extra working space.
- Using sharp tools, turn the blank down close to the bushing diameter. Turn the barrel straight or to a profile of your choice.
- Sand the blank down to be flush with the bushings, gradually increasing sandpaper grits.
- Finish the barrel using your choice of polish. Allow sufficient time for the polish to cure—refer to polish instructions.

## Assembly

- Press tip nut, recessed end first, into either end of the finished barrel.
- Thread plunger onto threaded stem inside the opening at the upper end of Back End Assembly.
- Press the Back End Assembly, **with plunger installed** recessed side first, into opposite end of the barrel. see below\*
- Insert refill, back end first, into opening at opposite end.
- Place spring on refill, the flared end of the spring must be at the tip for proper function.
- Screw tip onto the pen.
- To extend, push on the plunger—centerband will spin – until the mechanism locks into place.
- To retract pen tip, pull the Trigger Clip against the Back End assembly. This will release the mechanism and retract the refill.
- To replace refill, unscrew tip and remove old refill. Insert new refill as above. Make sure spring is oriented correctly.

## DIAGRAM C / BUSHINGS # PKREVB

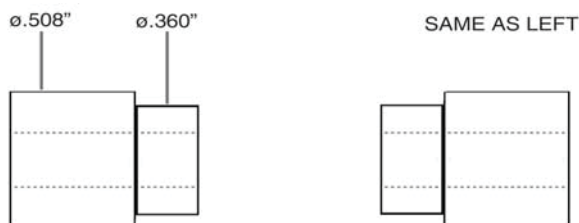

\*Pressing with the plunger installed may be necessary to condition the plunger/click operation