

LANCER PEN Instructions

Kit Features

- Smooth twist mechanism
- Parker™ style refills (RE-PARK)
- Overall length: 5-1/4"

Required Accessories & Materials

- 7mm mandrel
- 2-pc. Mesa bushing set (PKMESABU)
- Drill bit – 27/64" (DB27/64)
- Universal trimming kit (BTRIMKIT9)
- Glue (We recommend the thick "gel" CA glue—GTHICK2)
- Sanding and finishing supplies

Diagram A - Parts and Assembly

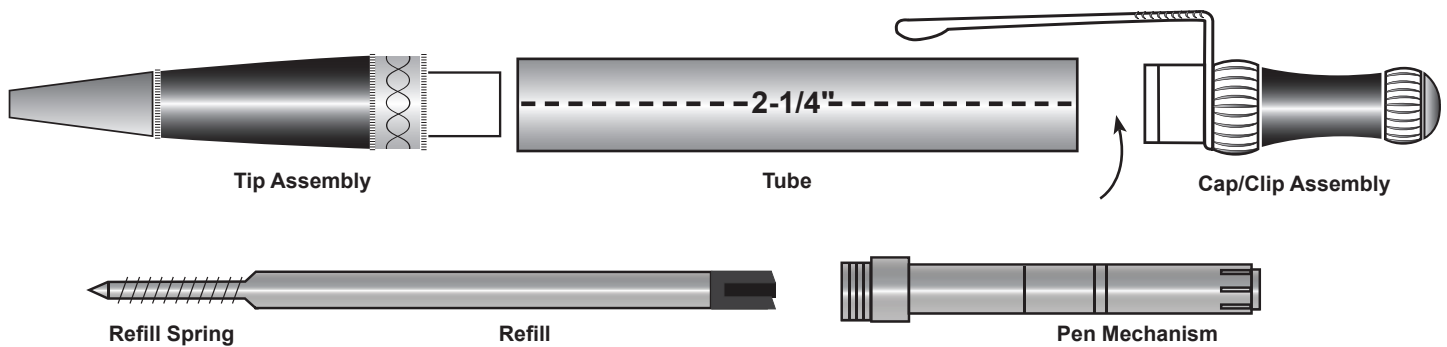

BLANK PREPARATION

The Lancer pen has a single tube measuring 2-1/4". **Cut** your blank approximately 1/16" longer than the tube to allow for squaring with the barrel trimmer. Use a medium drill speed to **drill** the blank. Raise the bit from the blank every 1/4" to 1/2" to allow the chips to clear from the flutes of the drill bit. Don't force the drill bit; use an even pressure and let the bit do the work. After drilling the blank, **sand** the exterior of the brass tube to roughen its surface and use CA **glue** to glue the tube inside the blank. Sand or barrel trim to **square** the ends of the blank.

TURNING THE PEN

Set up the mandrel as shown in Diagram C. The Lancer pen's upper and lower bushings both have an outside diameter of .470" (see Diagram B). **Turn** the pen blank to the bushing diameter at the ends. **Sand** with abrasives and **finish** with your choice of polish.

ASSEMBLY

(Line up finished parts according to Diagram A)
To avoid damage to components when assembling, use a vise with covered jaws or one of WoodTurningz' pen presses.

1. Slide the spring onto the refill and place inside the tip assembly. Screw the pen mechanism into the tip assembly.
2. Press clip assembly into the upper end of the barrel.
3. Push pen barrel with clip/cap assembly onto completed lower assembly.
4. The pen is now ready to operate; twist clockwise to open.

Diagram B - Bushings

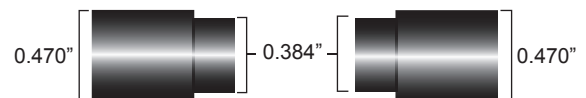

Diagram C - Turning the Pen

